



6 M26.3

The New Marine Power Reference



4 stroke diesel engine, direct injection, common-rail

Bore and stroke	150 x 150 mm
Number of cylinders	6 in line
Total displacement	15.9 litres
Compression ratio	15/1
Engine rotation (ISO 1204 standard)	counterclockwise
Idle speed	700 rpm
Flywheel housing	SAE 1
Flywheel	SAE 14"

Customer benefits

Genuine marine design with simple solutions, full service accessibility, engine block inspection hatches

Continuous compact power with reference performances in its category

Global environment care with low exhaust emissions and controlled fuel consumption at any running cycle

Latest safe technology including electronic injection dynamic redundancy, high efficient ball bearing turbocharger, integrated circuits with 0 flexible hoses, and more...

Life cycle cost efficiency with extended MTBO, reduced number of components and interfaces

Rated power - Fuel consumption

Duty	kW	hp	rpm	BFSC g/kWh*	IMO	EPA	CCNR	CE 97/68
P1	404	550	1600	206	II	-	II	IIIA
P1	441	600	1800	197	II	III	II	IIIA
P2	485	660	1800	207	II	-	II	IIIA
P2	515	700	2000	203	II	III	II	IIIA
P2	551	750	2100	209	II	III	II	IIIA
P3	599	815	2100	216	II	III	-	-

* Declared BSFC at IMO II rating

	P1	P2	P3
Application	unrestricted continuous	continuous	intermittent
Engine load variations	very little or none	numerous	important
Mean engine load factor	80 to 100%	30 to 80%	50%
Annual working time	more than 5000 h	3000 to 5000 h	1000 to 3000 h
Time at full load	unlimited	8 h each 12 h	2 h each 12 h

Power definition

(Standard ISO 3046/1 - 1995 (F))

Reference conditions

Ambient temperature	25 °C / 77 °F
Barometric pressure	100 kPa
Relative humidity	30%
Raw water temperature	25 °C / 77 °F

Fuel oil

Relative density	0,840 ± 0,005
Lower calorific power	42 700 kJ/kg
Consumption tolerances	0 ± 5%
Inlet limit temperature	35 °C / 95 °F

Our ratings also comply with classification societies maximum temperature definition without power derating.

Ambient temperature	45 °C / 113 °F
Raw water temperature	32 °C / 90 °F



Standard equipment

Cooling system	Two stages cooling circuit with built in HT thermostatic valve Integrated fresh water expansion tank High efficiency tubular heat exchanger Gear driven centrifugal fresh water pump Self priming raw water pump with bronze impeller
Lubrication system	Full flow lube oil filters duplex type - Centrifugal lube oil purifier Fresh water cooled lube oil heat exchanger Manual priming and draining pump
Fuel system	Common-rail electronic injection High pressure pump with shielded high pressure injection rail and pipes Fuel oil filter duplex type Water separator
Intake air and exhaust system	Double flow raw water cooled intake air heat exchanger module Fresh water cooled exhaust gas manifold High efficiency dry turbocharger with ball bearing technology
Electrical system	Voltage: 24VDC insulated Electrical starter 190A battery charger

Optional solutions (extract)

Cooling circuit configuration for box/keel cooling
Application injection map (Eco mode - Comfort - High performance)
Integral electronic injection ECU dynamic redundancy
High efficiency air filter with blow-by recycler
Equipment and factory trial according to Classification Societies

Dimensions and dry weight (mm / kg)

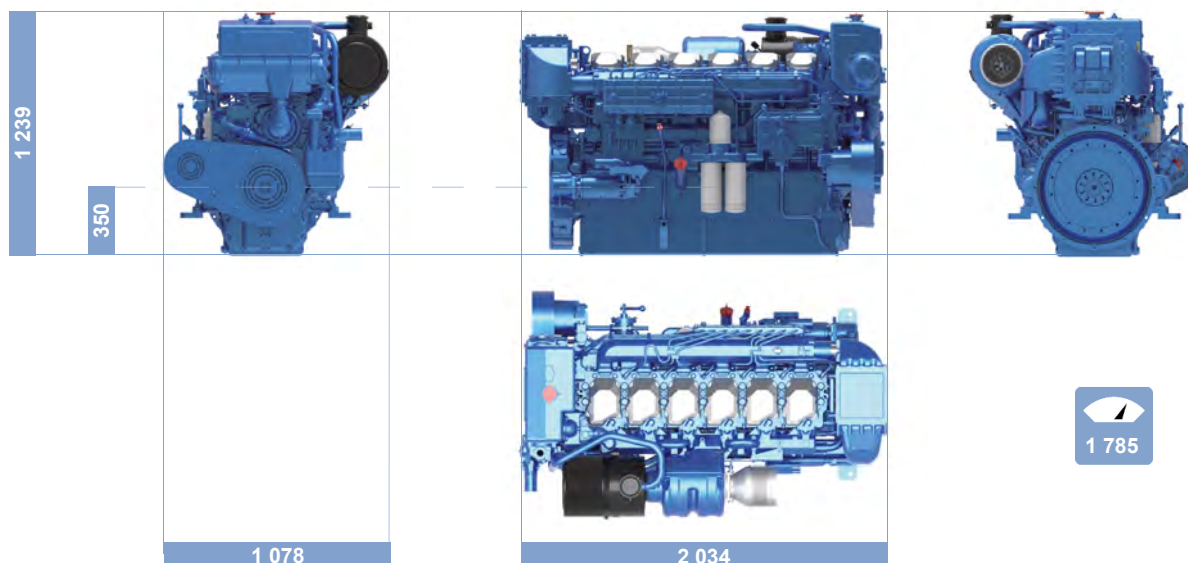

Connections

Raw water inlet	Raw water outlet	Fuel inlet	Fuel outlet	Exhaust
Ø 76.1 mm	Ø 2 x 60 mm	Ø 22 mm	Ø 22 mm	Ø 194 mm