

6 W126M



Not contractual picture

4 stroke diesel engine, direct injection

Bore and stroke	126 x 155 mm
Number of cylinders	6 in line
Total displacement	11.6 litres
Compression ratio	17/1
Engine rotation (ISO 1204 standard)	CCW *
Idle speed	600 rpm
Weight (without water & oil)	1200 kg
Flywheel housing	SAE 1
Flywheel	SAE 14"

* counter-clockwise

RATED POWER

Duty	rpm	kW	hp	Peak torque / speed (N.m / rpm)	Full load fuel consumption (g / kW.h)	IMO	CCNR
P1	1800	294	400	1914 / 1000	200	II	II
P2	2100	331	450	2004 / 1200	210	II	II

STANDARD EQUIPMENTS

Engine and block

- Cast iron cylinder block, with replaceable cylinder liners
- Separate cast iron cylinder heads equipped with 4 valves
- Replaceable valves guides and seats
- Steel forged crankshaft with 7 bearings
- Lube oil cooled light alloy piston with 3 high performance piston rings

Cooling system

- Fresh / raw water heat exchanger with integrated thermostatic valves and expansion tank
- Cast iron centrifugal fresh water pump, mechanically driven
- Bronze self-priming raw water pump, mechanically driven

Lubrication system

- Full flow duplex type oil filters
- Fresh water cooled lube oil cooler

Fuel system

- In line injection pump with flanged mechanical governor
- Double wall injection bundle
- Duplex fuel filters replaceable engine running
- Water separator

Intake air and exhaust system

- Insulated exhaust gas manifold
- Turbo blower with insulated turbine housing
- Low water temperature cooled intake air cooler

Electrical system

- Voltage: 24Vcc
- Electrical starter on flywheel crown
- 35A battery charger

OPTIONAL EQUIPMENTS (extracts) *

- Cooling system adapted for box / keel cooling
- Connection for emergency raw water circuit
- Bilge pump
- Air starter

- Free end PTO
- Resilient mounts under engine
- Exhaust water injection after turbocharger

* contact us for further information regarding our options.

Power definition

Standard ISO 3046/1 - 1995 (F)

Reference conditions

Ambiant temperature	25 °C / 77 °F
Barometric pressure	100 kPa
Relative humidity	30 %
Raw water temperature	25 °C / 77 °F

Limit conditions ISO 3046

Fuel oil

Relative density	0,840 ± 0,005
Lower calorific power	42 700 kJ/kg
Consumption tolerances	0 ± 5 %
Inlet limit temperature	35 °C / 95 °F

Our ratings also comply with classification societies maximum temperature definition without power derating.

Ambiente temperature	45 °C / 113 °F
Raw water temperature	32 °C / 90 °F

	P1 duty	P2 duty
Application	unrestricted continuous	continuous
Engine load variations	very little or none	numerous
Mean engine load factor	80 to 100 %	30 to 80 %
Annual working time	more than 5000 h	3000 to 5000 h
Time at full load	unlimited	8 h each 12 h

P1 typical applications

deep sea trawlers, shrimps trawlers, sea going tug boats, river tug boats, push boats, freighters, dredges, LCT, ferries

P2 typical applications

passengers vessels, harbour tug boats, motorbarges, coastal freighters, tuna boats, seiners, netters, potting boats, longliners, buoyers, supply vessels, oceanographic research vessels, commercial pleasure crafts

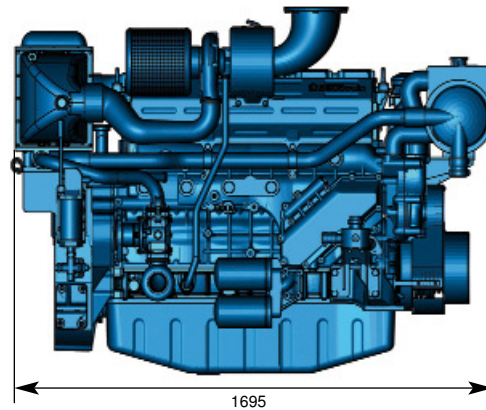
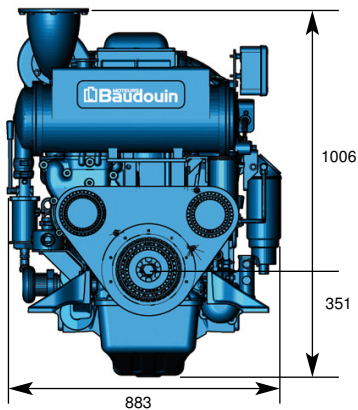
DIMENSIONS**PERFORMANCES**

P1 rating - 294 kW / 400 hp @ 1800 rpm

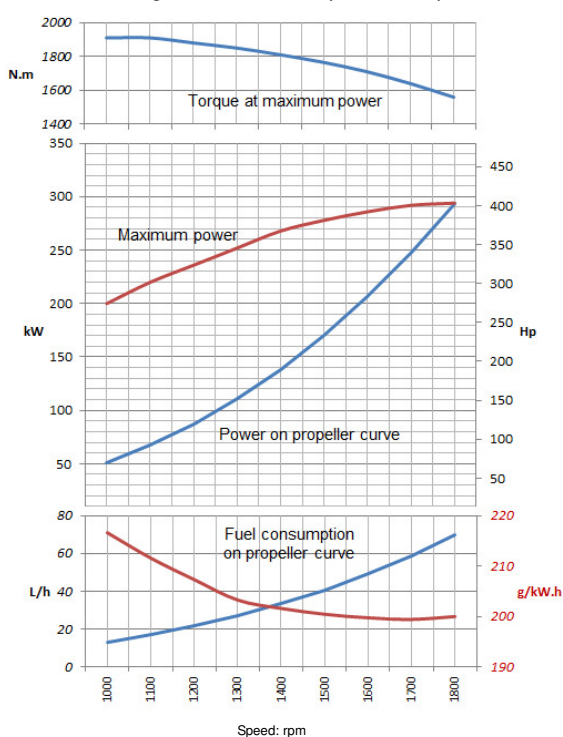

P2 rating - 331 kW / 450 hp @ 2100 rpm

