

6 M33.2



Not contractual picture

4 stroke diesel engine, direct injection

Bore and stroke	150 x 185 mm
Number of cylinders	6 in line
Total displacement	19.6 litres
Compression ratio	15/1
Engine rotation (ISO 1204 standard)	Counterclockwise
Idle speed	650 rpm
Dry weight	2390 kg
Flywheel housing	SAE 1
Flywheel	SAE 14"

RATED POWER: E3 cycle

Duty	rpm	kW	hp	Peak torque / speed (Nm / rpm)	Full load fuel consumption (g/kWh)	IMO
P1	1800	478	650	3056 / 1300	211	II
P1	1800	515	700	3085 / 1300	209	II
P2	1800	551	750	3684 / 1400	214	II

Power definition Standard ISO 3046/1 - All units are metric and declared performances according to IMO Tier II ratings

Reference conditions

Ambient temperature	25 °C / 77 °F
Barometric pressure	100 kPa
Relative humidity	30%
Raw water temperature	25 °C / 77 °F

Fuel oil

Relative density	0,840 +/- 0,005
Lower calorific power	42 700 kJ/kg
Consumption tolerances	+/- 5%

	P1 duty	P2 duty
Application	Unrestricted continuous	Continuous
Engine load variation	Very little or none	Numerous
Mean engine load factor	80 to 100%	30 to 80%
Annual working time	More than 5000 hr	3000 to 5000 hr
Time at full load	unlimited	8 hr every 12 hr

STANDARD EQUIPMENTS

Engine and block

- Cast iron cylinder block
- One inspection door per cylinder for access to conrod cap
- Cast iron cylinder liners, wet type
- Separate cast iron cylinder heads equipped with 4 valves
- Replaceable valves guides and seats
- Hardened steel forged crankshaft with induction hardened journals, crankpins and radius
- Lube oil cooled light alloy pistons with high performance piston rings

Cooling system

- Fresh / raw water heat exchanger with integrated thermostatic valves and expansion tank
- Cast iron centrifugal fresh water pump, mechanically driven
- Bronze self-priming raw water pump, mechanically driven

Lubrication system

- Full flow screwable oil filters
- Lube oil purifier with replaceable cartridge
- Fresh water cooled lube oil cooler
- Manual prelubricating oil pump

Fuel system

- In line injection pump with flanged mechanical governor
- Double wall injection bundle with leakage collector
- Duplex fuel filters replaceable engine running

Intake air and exhaust system

- Fresh water cooled turbo blower
- Fresh water cooled exhaust gas manifold

Electrical system

- Voltage: 24VDC
- Engine room and bridge panels
- Electrical starter on flywheel crown
- 175A battery charger

DIMENSION (mm)

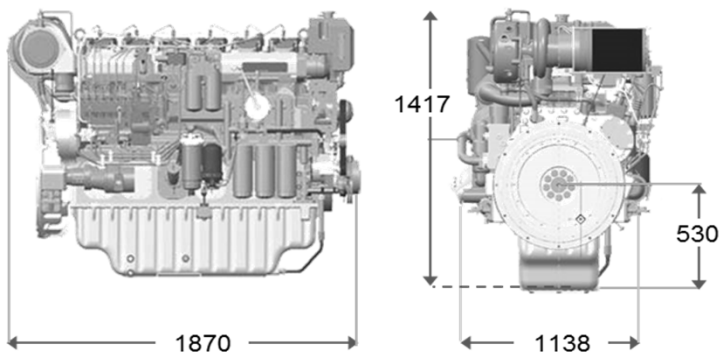

PERFORMANCES

P1 rating - 478 kW / 650 hp @ 1800 rpm

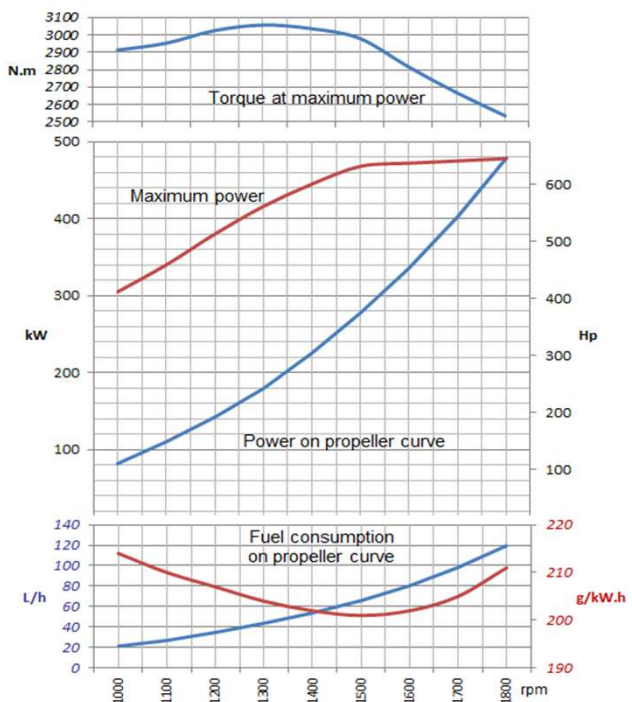

P1 rating - 515 kW / 700 hp @ 1800 rpm

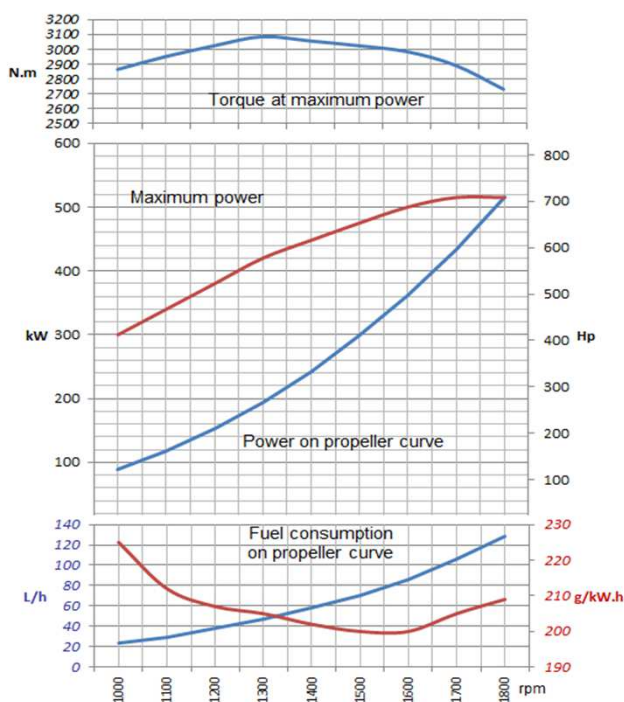

P2 rating - 551 kW / 750 hp @ 1800 rpm

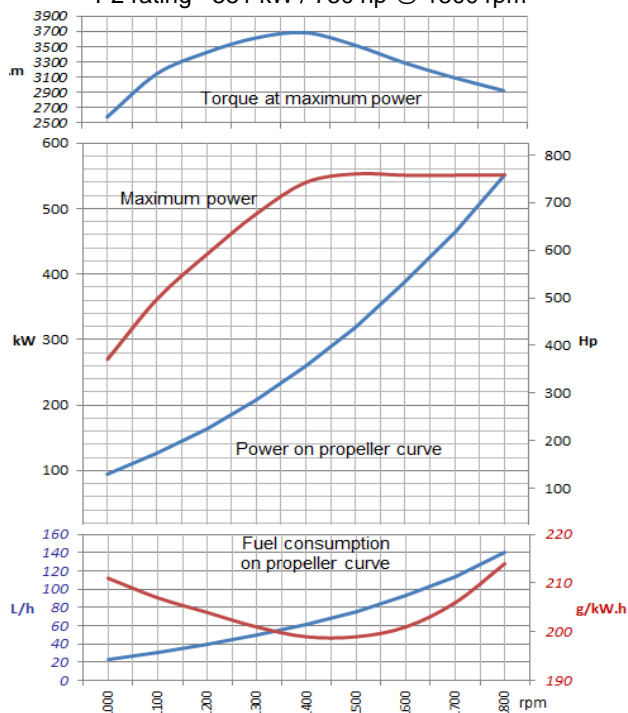

Moteurs Baudouin reserve the right to modify these specifications without notice. Document not contractual