

PROPILOT

Joystick Control System





“We’ve owned our boat for five years now and Tricia has never docked it, but today she did it twice - and in a crosswind!”

**Capt. Bill Chambers,
Fleming Yacht owner**

The ProPilot control offers the boater an extremely simple and intuitive means of controlling the complete propulsion system of their boat using a single joystick interface.

PROPILLOT



Move or rotate the ProPilot joystick and the boat will move in that same direction

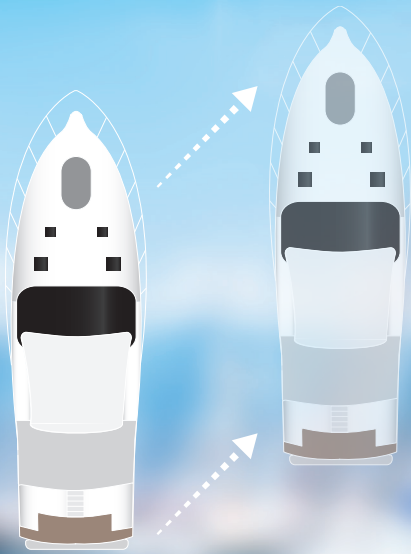

Power Boat

Twin inboard with bow thruster.



Sail Boat

Single inboard with bow and stern thruster.

The ProPilot is an optional accessory that can be added to most existing and any new Glendinning control systems on boats with inboard propulsion and bow / stern thrusters.

By combining the available thrust of the boats engine(s) and thruster(s) the Glendinning ProPilot system allows simple and intuitive boat handling even in the most unfavorable winds or currents.

Maneuvering and docking is made easy using the single joystick control. By simply moving or rotating the ProPilot joystick, the engine(s) and thruster(s) will activate to effortlessly move the boat in the required direction.

The ProPilot system is suitable for installation on all twin inboard engine powerboats with bow thrusters (or bow and stern thrusters), and sailboats with both bow and stern thrusters fitted.

An integrated thruster control keypad provides the capability to control the thrusters directly without the need for a separate thruster panel.

Installation is extremely easy since the ProPilot joystick can be added to existing helm stations control heads with a short CANbus cable, and connected to the helm station thruster controls with plug in connectors for any brand or type of bow/stern thruster. The joystick function is customized (balanced) for each vessel using an easy to use PC program.



System Schematic

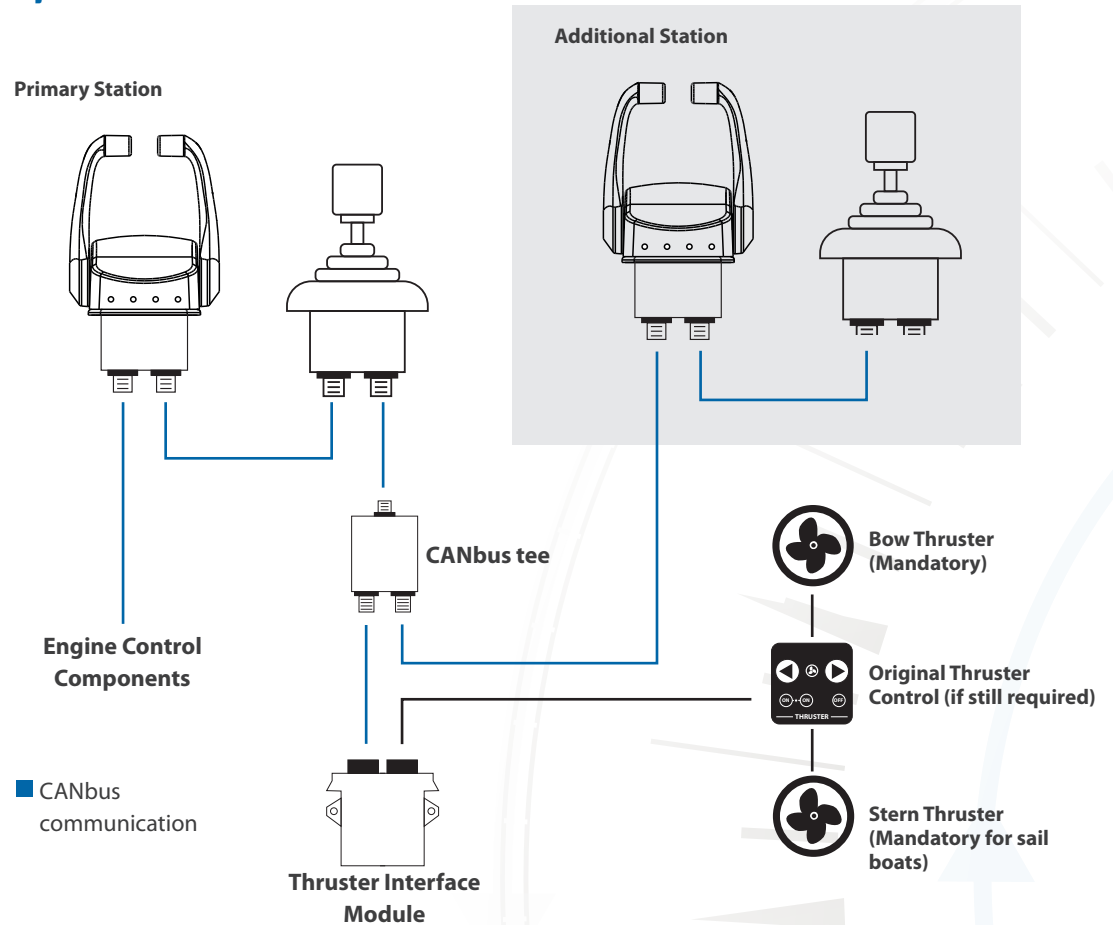

Dimensions

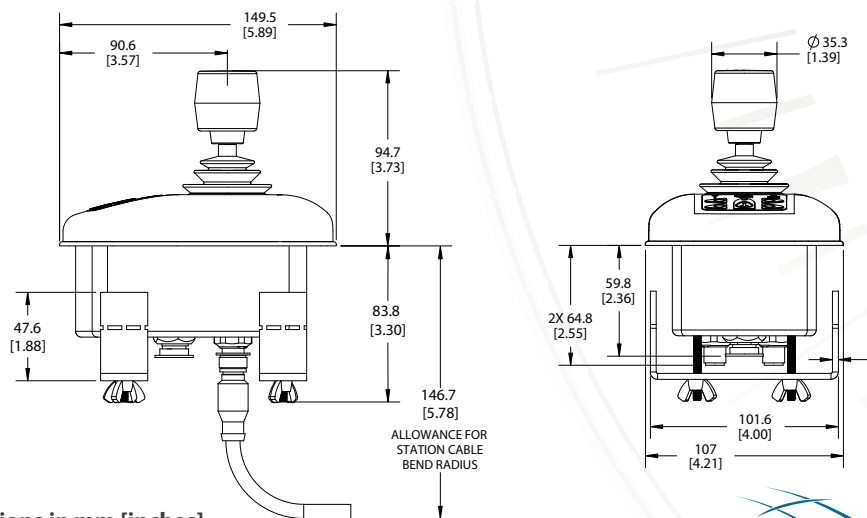

Dimensions in mm [inches]

Suitable for the following boats:

- > Power boats with twin inboard engines and bow thruster (stern thruster optional)
- > Sail boats with bow and stern thrusters (compatible with retractable thrusters)

Compatible with the following engine/drive configurations:

- > Mechanical or electronically controlled engine throttles
- > Mechanical or electrically shifted transmissions
- > Mechanical or electrically controlled trolling valves (optional)

For use with all thruster brands and types, including:

- > Electric
- > Hydraulic
- > Single speed
- > Proportional

Glendinning Controls Overview

Since 1996 when their first electronic control system was introduced to the marine market, Glendinning has built a reputation for delivering reliable, innovative engine control systems for all applications.

Working directly with engine manufacturers and boat builders worldwide, thousands of systems have been installed over the years.

Glendinning controls are engineered to be compatible with all electronic and/or mechanical and engines and transmissions so there is a system to suit all applications, including:

- > Sterndrives
- > Saildrives
- > Inboards
- > Outboards
- > Water Jets

CANbus technology makes for an uncomplicated installation and allows easy routing of single small gauge communication cables to add stations as required.



Top Mount Controls

For single or twin engines, with or without tilt/trim/troll.



ProPilot

Joystick Control System



Sail Boat Control



Palm Beach Control



Wired Remote Control

There's a complete range of control head styles to choose from and optional selectable features as required including a complete and truly automatic integrated "back up" system.

Standard Key Features

- > Single lever control (throttle and shift in one handle)
- > 6 station capability
- > Posi-Lock gear lock out (warm mode)
- > Engine synchronisation
- > Start interlock
- > Dual battery inputs
- > Dimmable keypad
- > Full diagnostic review
- > 12v and 24volt

Optional Features

- > Handheld remote control
- > Trolling valve control
- > Integrated back up system
- > Trim/Tilt control (Outboard/Sterndrives)
- > ProPilot joystick control system (Inboard boats only)



All Glendinning controls are compatible with the new ProPilot joystick option.

Cablemaster CR Cord Reel Systems

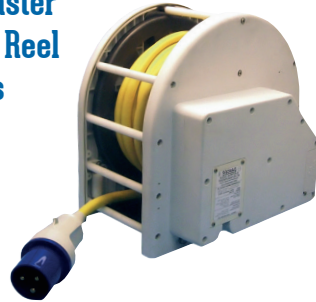

- › Self-contained compact design
- › Zero load pull out force
- › Powered retraction
- › 16amp-50amp+ options

Cablemaster CM Handling Solutions



- › Powered extension/retraction
- › Coils cable into container below deck
- › Suits all cable sizes (16amp – 200amp+)
- › Wireless control option

Hosemaster Hose Reel Systems



- › Efficient storage of water/air hoses
- › Zero load pull out force
- › Robust marine construction
- › Easy installation

Pro-X Engine Control Cables



- › Pro-X high performance technology
- › Maximum efficiency
- › Minimal lost motion
- › 3 year warranty



Glendinning Products, LLC.

740 Century Circle, Conway, SC 29526-8274

t: +1 (843) 399-6146 | e: info@glendinningprods.com | f: +1 (843) 399-5005

www.glendinningprods.com

